

...a modern classic window system

## Heritage needn't mean compromise

The Vertical Slider Window System from **VEKA** brings together three powerful elements – one of today's most popular window styles, the industry-leading fully sculptured Matrix FS profile system and the world renowned **VEKA** brand.

Now fabricators and installers can offer a vertical sliding window with the technical excellence and superb good looks that come with this highly-acclaimed frame system coupled with a name that is respected by specifiers everywhere – **VEKA**.

Now available with the coveted 'A' Window Energy Rating – combining traditional aesthetics with the very best in performance.

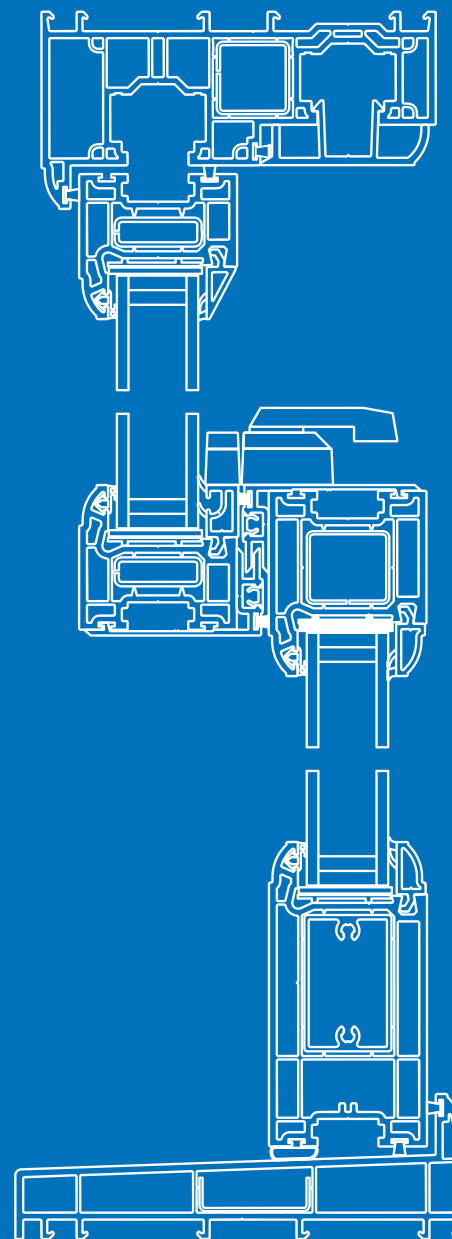

### The Vertical Slider Window System from **VEKA**

A rating available

Run-through sash horns available

Slimline sash

Range of colours including foil on white and white woodgrain



**NEW VEKA**  
Vertical Slider



VEKA plc



Vertical Slider Window System

VEKA plc Farrington Road, Rossendale Road Ind. Est, Burnley, Lancashire, BB11 5DA.

Tel: 01282 716611 Fax: 01282 725257 e-mail: [salesenquiry@veka.com](mailto:salesenquiry@veka.com)

[www.vekauk.com](http://www.vekauk.com)



For the best profile... anywhere

# The NEW VEKA Vertical Slider

## ...a modern classic window system

VEKA continually invests in its profile systems to ensure they are the most technically advanced on the market. The VEKA Vertical Slider system now has a host of additional features:

1. **NEW** Run-through Sash Horn – offering enhanced aesthetics to complement the traditional sash window style
2. **NEW** Sash Stop End Cap – neat aesthetics and a perfect seal to prevent debris such as leaves entering the profile
3. **NEW** Blanking Strip – ensures a perfect interior and exterior finish for foiled on white windows
4. **NEW** Interlock – enhanced structural stability
5. **NEW** Bottom Gasket – minimises draughts
6. **NEW** – 'A' Rating now available

### The choice of fabricators:

Advanced design enables quick and efficient frame fabrication and glazing with a maximum frame size of 1400mm X 2400mm.

### The choice of installers:

Slimline outer frame (136mm X 68mm) improves installation flexibility – but retains complete compatibility with existing VEKA fixing brackets.

### The choice of homeowners:

A great looking window ensures strong demand from the retrofit sector as well as new-build. The pleasing slimline appearance belies a high performance energy efficient design. Slimline sashes offer improved window aesthetics and maximised Window Energy Rating performance.

### The choice of specifiers:

VEKA remains the No.1 choice of social and commercial specifiers throughout Britain and Ireland with a reputation second-to-none for technical excellence and superb good looks. The VEKA Vertical Slider System has been specified for use in conservation areas and listed buildings.



### More choice

#### COLOURS:

- Brilliant White • Golden Oak on Caramel
- NEW Golden Oak on White • Rosewood on Brown
- NEW Rosewood on White • White Woodgrain
- White on White

#### HORNS:

- NEW run-through horns now available
- Clip-in horns also available
- Available without horns for a more contemporary look

#### CILL:

- Universal design allows for either overhanging or stub cill.
- Rear projection resulting in less complex fabrication.
- Standard leg detail enables the use of existing VEKA fixing brackets.

#### GEARING:

- Bespoke gearing features to allow fabricators free choice of suppliers including heavy duty spring balances
- Profile allows for correct and secure location of gearing fittings
- Provision for fitting of trickle vents within frame head

#### GLAZING THICKNESS:

- Designed primarily for use with 28mm glazing thickness
- Can be used with Matrix 58 bead range to accommodate other glazing thicknesses if required

#### BOTTOM SASH:

- Choice of two bottom sash options – Four-sided fully welded or Three-sided fully welded
- Mechanically coupled deep bottom rail
- NEW bottom gasket

